



FUJII ELECTRIC

**SPLIT TYPE ROOM
AIR CONDITIONER**

WALL MOUNTED type

SERVICE MANUAL

Models	Indoor unit	Outdoor unit
	RSW-17AC	ROW-17AC

C O N T E N T S

SPECIFICATIONS	1
REFRIGERANT SYSTEM DIAGRAM	2
CIRCUIT DIAGRAM	3
INDOOR PRINTED CIRCUIT BOARD CIRCUIT DIAGRAM	4
INDOOR P.C. BOARD LAYOUTS	5
DISASSEMBLY ILLUSTRATION	6
PARTS LIST	10



Большая библиотека технической документации

<https://splitsystema48.ru/instrukcii-po-ekspluatácii-kondicionerov.html>

каталоги, инструкции, сервисные мануалы, схемы.

S P E C I F I C A T I O N S

INDOOR UNIT		RSW-17AC
OUTDOOR UNIT		ROW-17AC
COOLING CAPACITY	(kW)	4.75 - 4.90

ELECTRICAL DATA

POWER SOURCE	(V)		220 - 240
FREQUENCY	(Hz)		50
RUNNING CURRENT	(A)	COOLING	9.5 - 10.1
		HEATING	—
INPUT WATTS	(kW)	COOLING	1.98 - 2.15
		HEATING	—
EER	(W/W)	COOLING	2.40 - 2.28
		HEATING	—
MOISTURE REMOVAL	(ℓ/hr)		2.1
AIR CIRCULATION-Hi	(m³/hr)		540

COMPRESSOR

TYPE	Hermetic type, Permanent split condenser, 2 pole, Single phase, Induction motor
CODE	2JS350D5BB02

FAN MOTOR

		INDOOR UNIT	OUTDOOR UNIT
MODEL		RSW-17AC	ROW-17AC
TYPE		MFA - 17AT	MFB - 247FBT
POWER SOURCE (V)		220 - 240	
FAN SPEED	HI-SPEED (r.p.m.)	1,240	740
	MED-SPEED (r.p.m.)	1,160	
	LO-SPEED (r.p.m.)	1,080	

DIMENSIONS

HEIGHT x WIDTH x DEPTH	(mm)	285 x 900 x 172	643 x 840 x 336
------------------------	------	-----------------	-----------------

WEIGHT

GROSS / NET	(kg)	13 / 10	63 / 55
-------------	------	---------	---------

REFRIGERANT CHARGING

PIPE LENGTH	16 ft (5 m)	23 ft (7 m)	33 ft (10 m)	49 ft (15 m)	66 ft (20 m)
FULL CHARGE AMOUNT	45.9 oz (1,300 g)	44.6 oz (1,320 g)	47.6 oz (1,350 g)	49.4 oz (1,400 g)	51.1 oz (1,450 g)

Note : Between 5 m and 20 m, when using a connection pipe other than that in the table,
charge additional refrigerant with 0.4 oz (10 g) / 3.3 ft (1 m) as the criteria.

REFRIGERANT SYSTEM DIAGRAM

Models : RSW-17AC / ROW-17AC

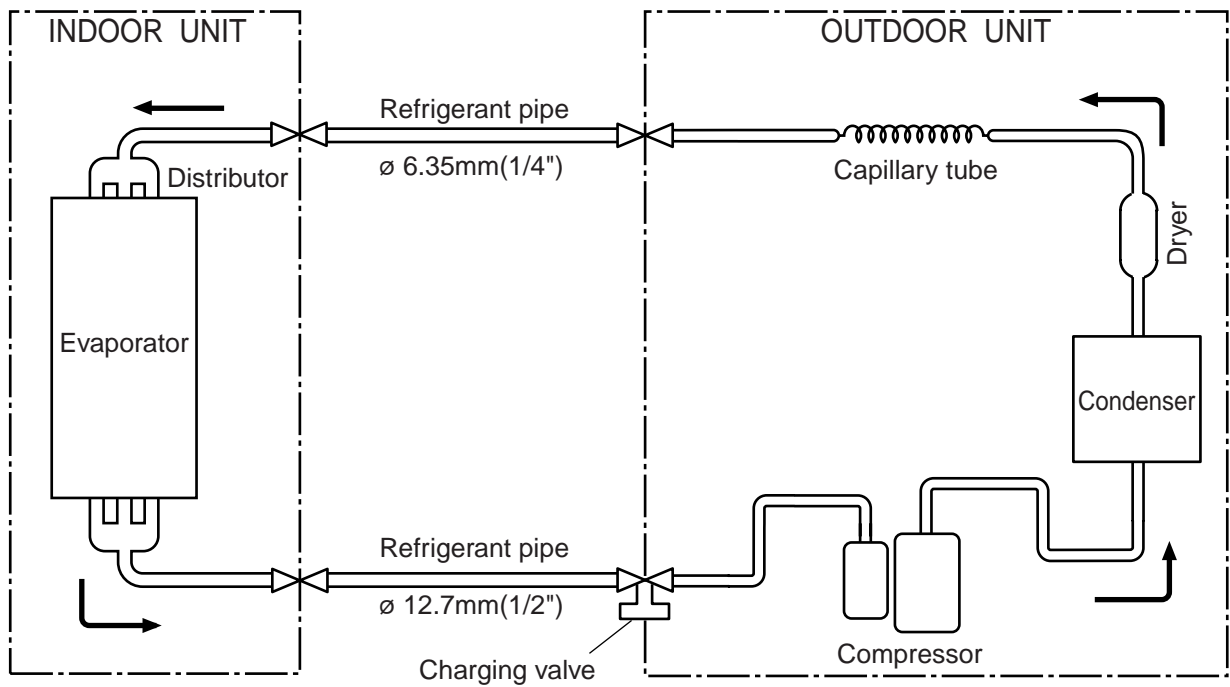

→ Cooling

⊗ : Flare coupling

CIRCUIT DIAGRAM

Models : RSW-17AC / ROW-17AC

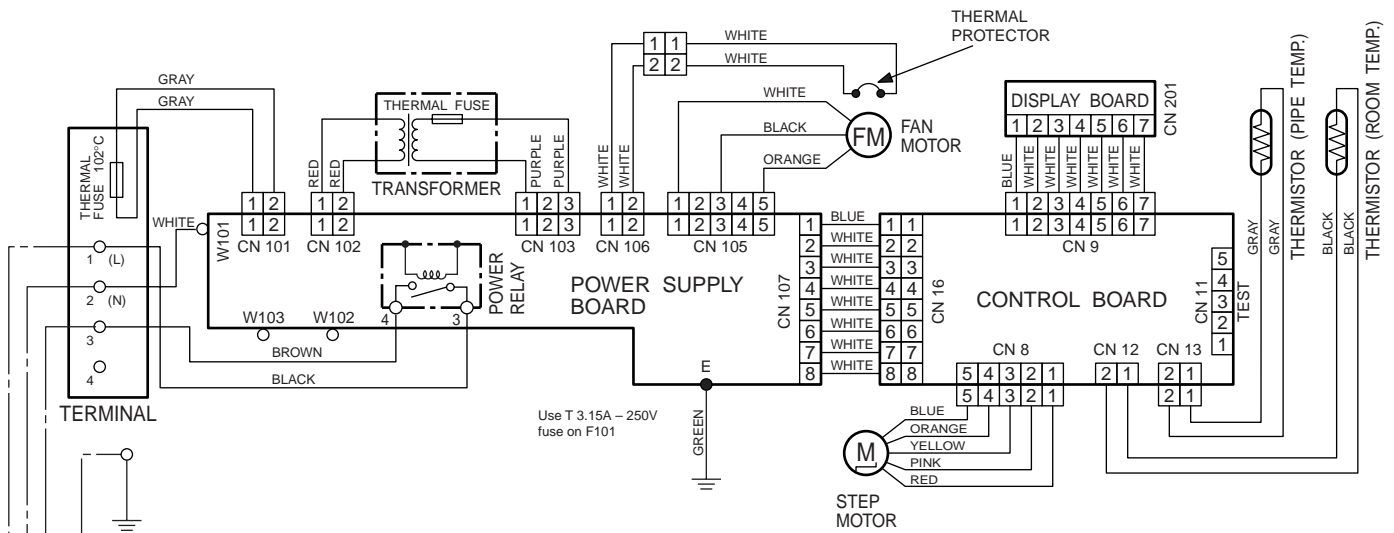

INDOOR UNIT
OUTDOOR UNIT

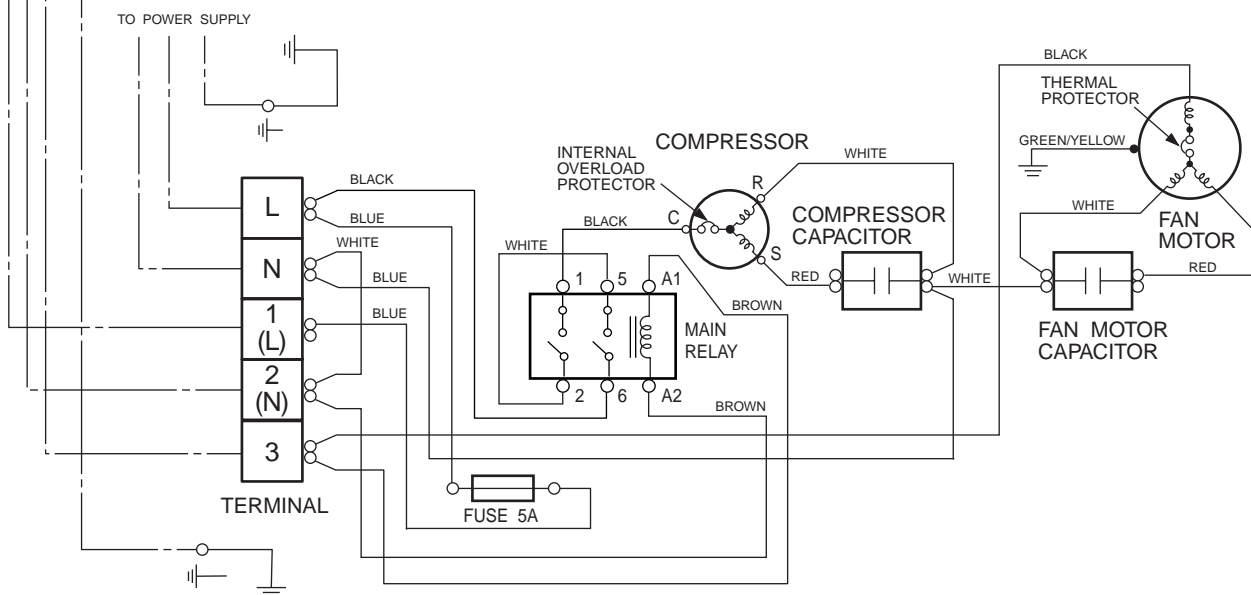

INDOOR PRINTED CIRCUIT BOARD CIRCUIT DIAGRAM

Model : RSW-17AC

CONTROLLER PCB ASSEMBLY (MAIN PCB) EZ-095GWSE-C (GM-6805)

POWER SUPPLY PCB EZ-099PWSE-P

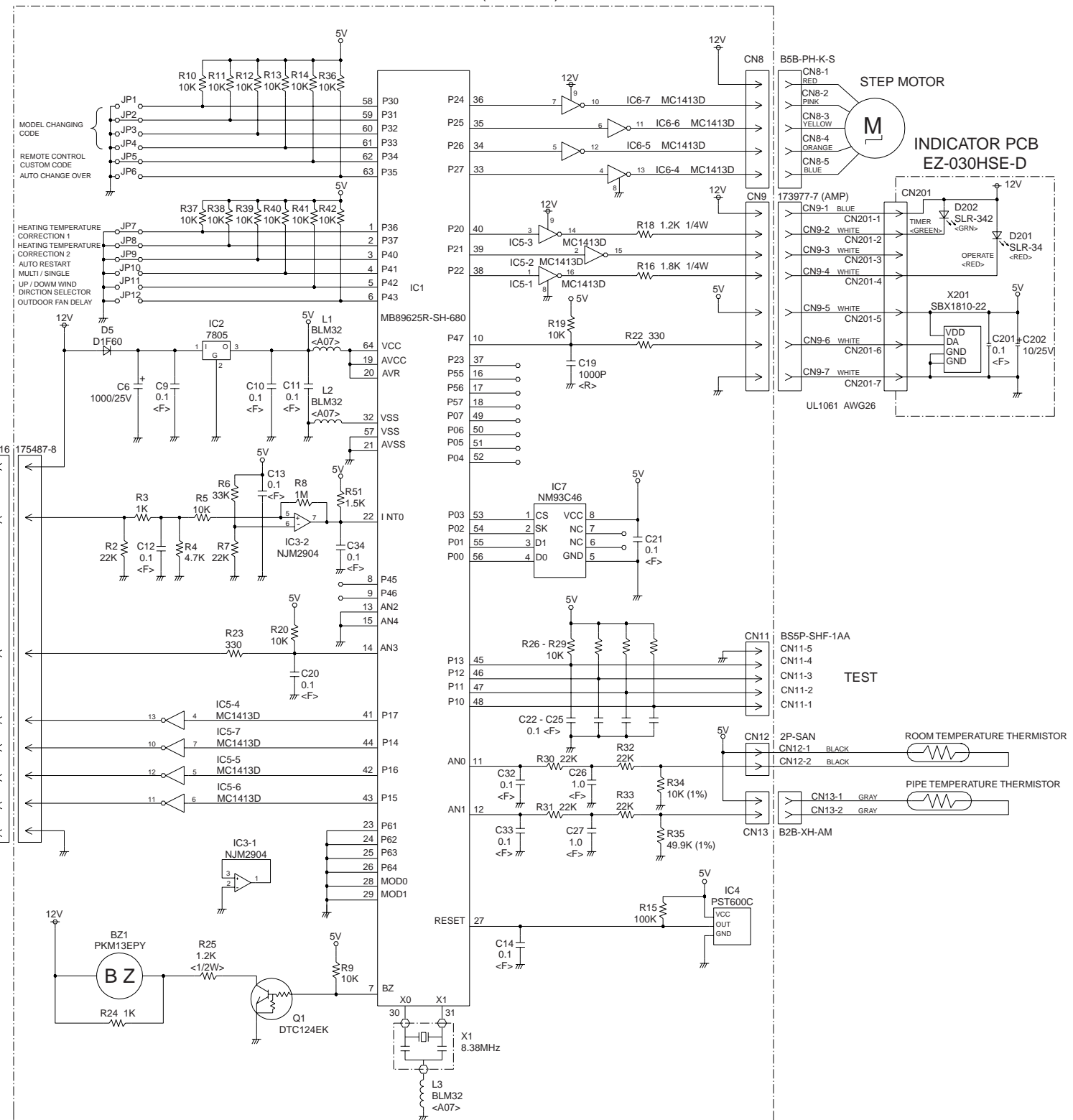
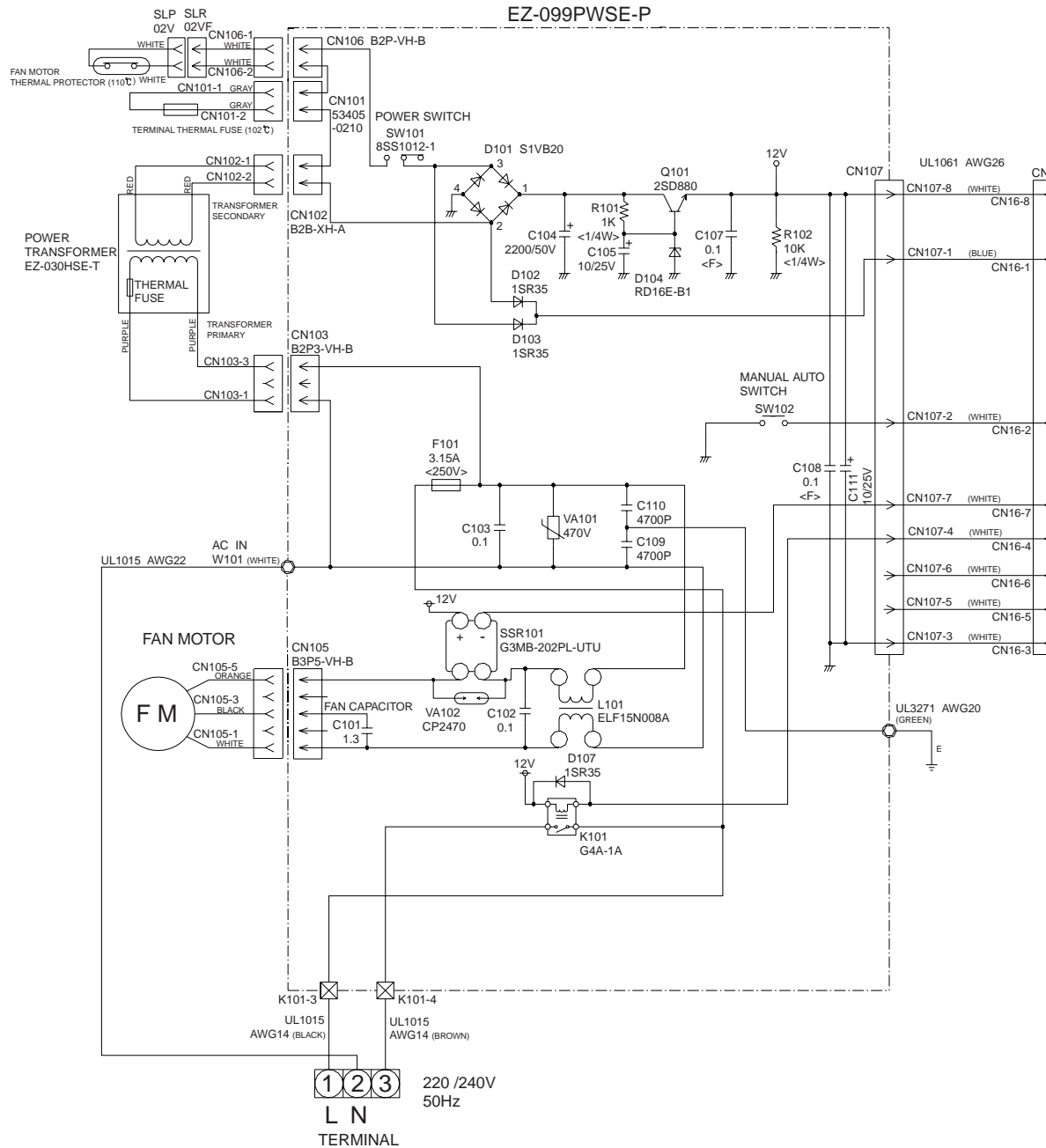

INDOOR P.C. BOARD LAYOUTS

CONTROLLER P.C. BOARD ASSEMBLY (MAIN PCB)

(Viewed from the solder side)

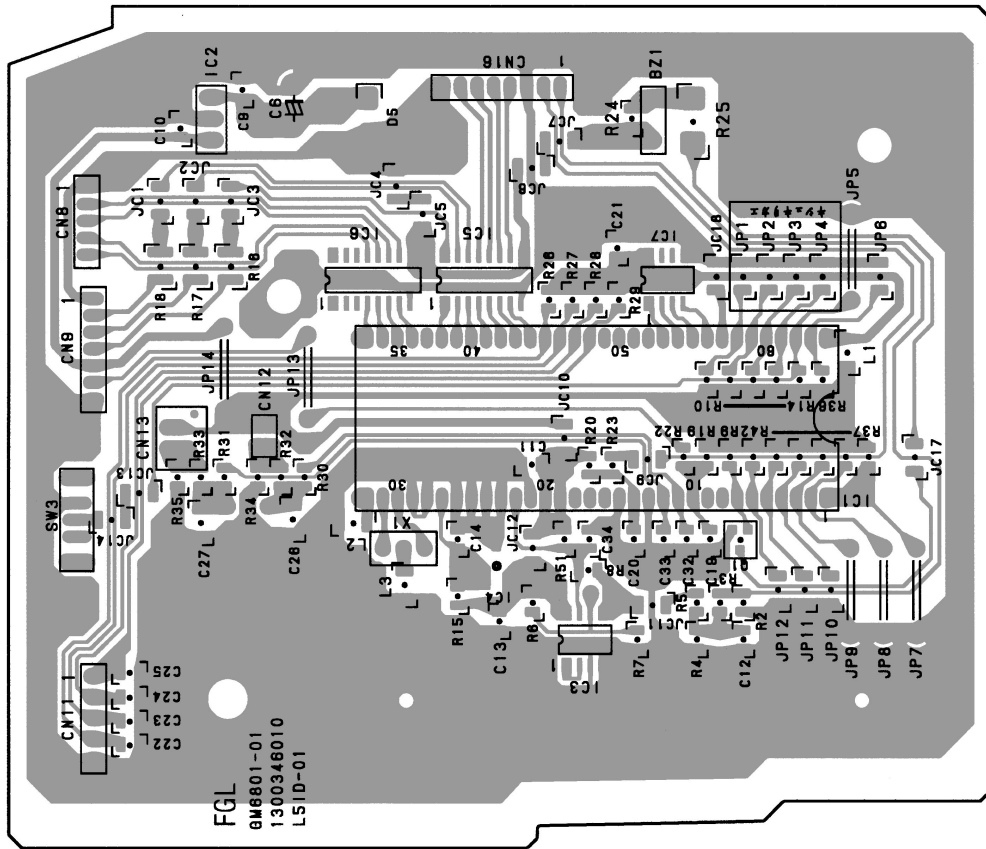

POWER SUPPLY P.C. BOARD ASSEMBLY

(Viewed from the solder side)

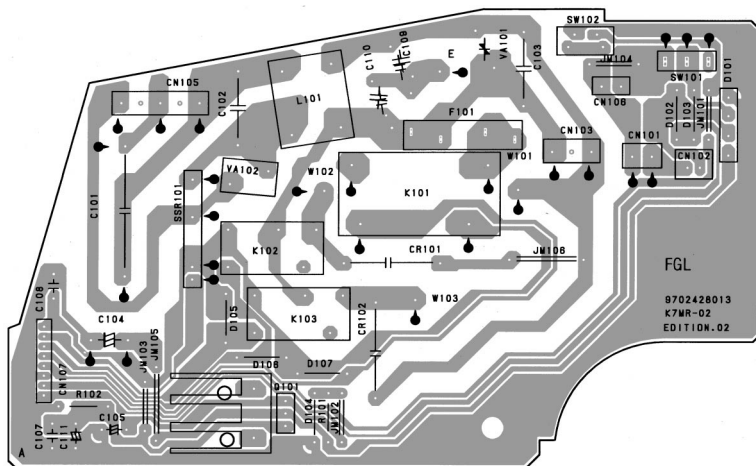

INDICATOR P.C. BOARD ASSEMBLY

(Viewed from the solder side)

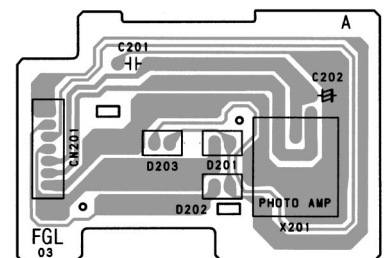

DISASSEMBLY ILLUSTRATION

Model : RSW-17AC

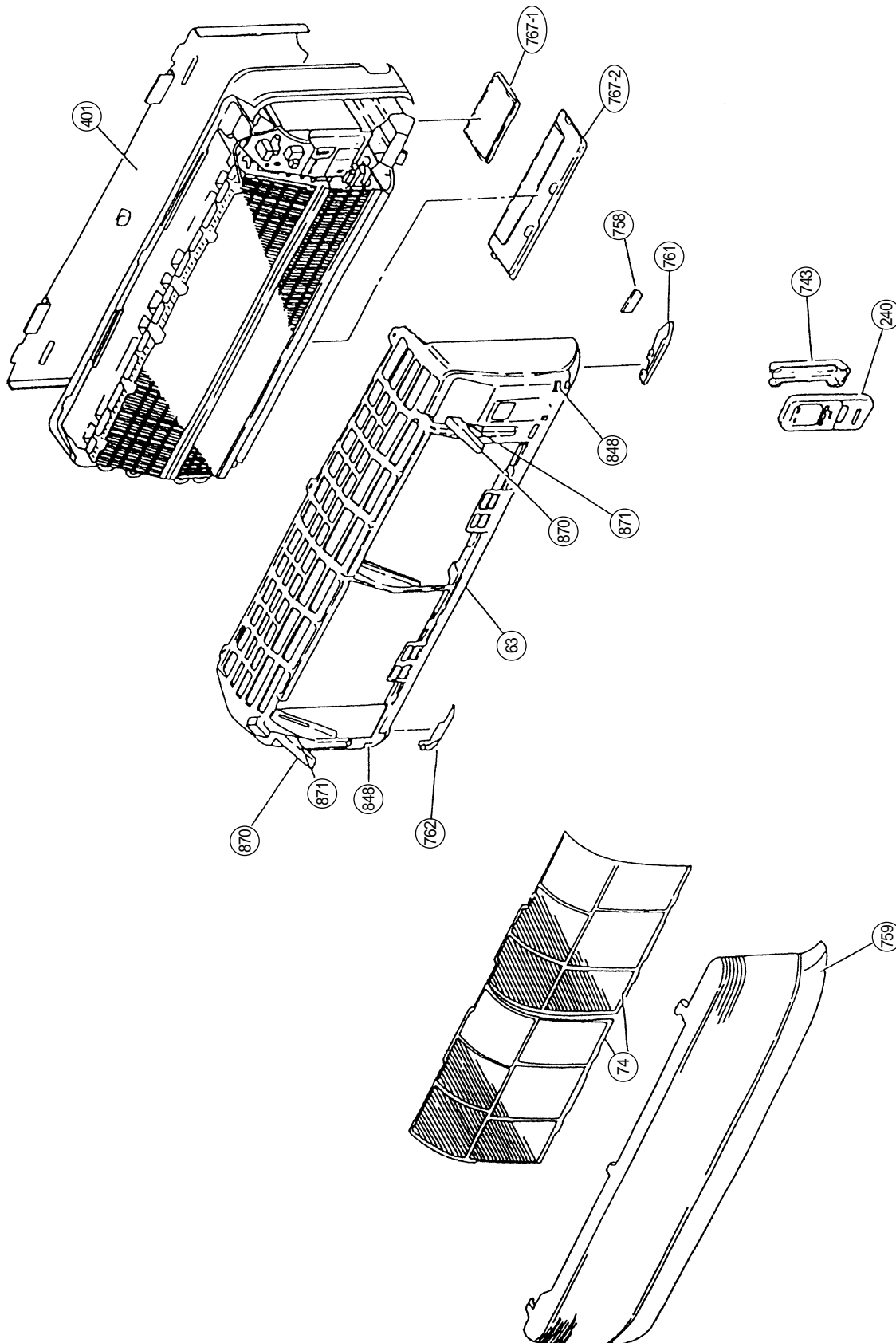

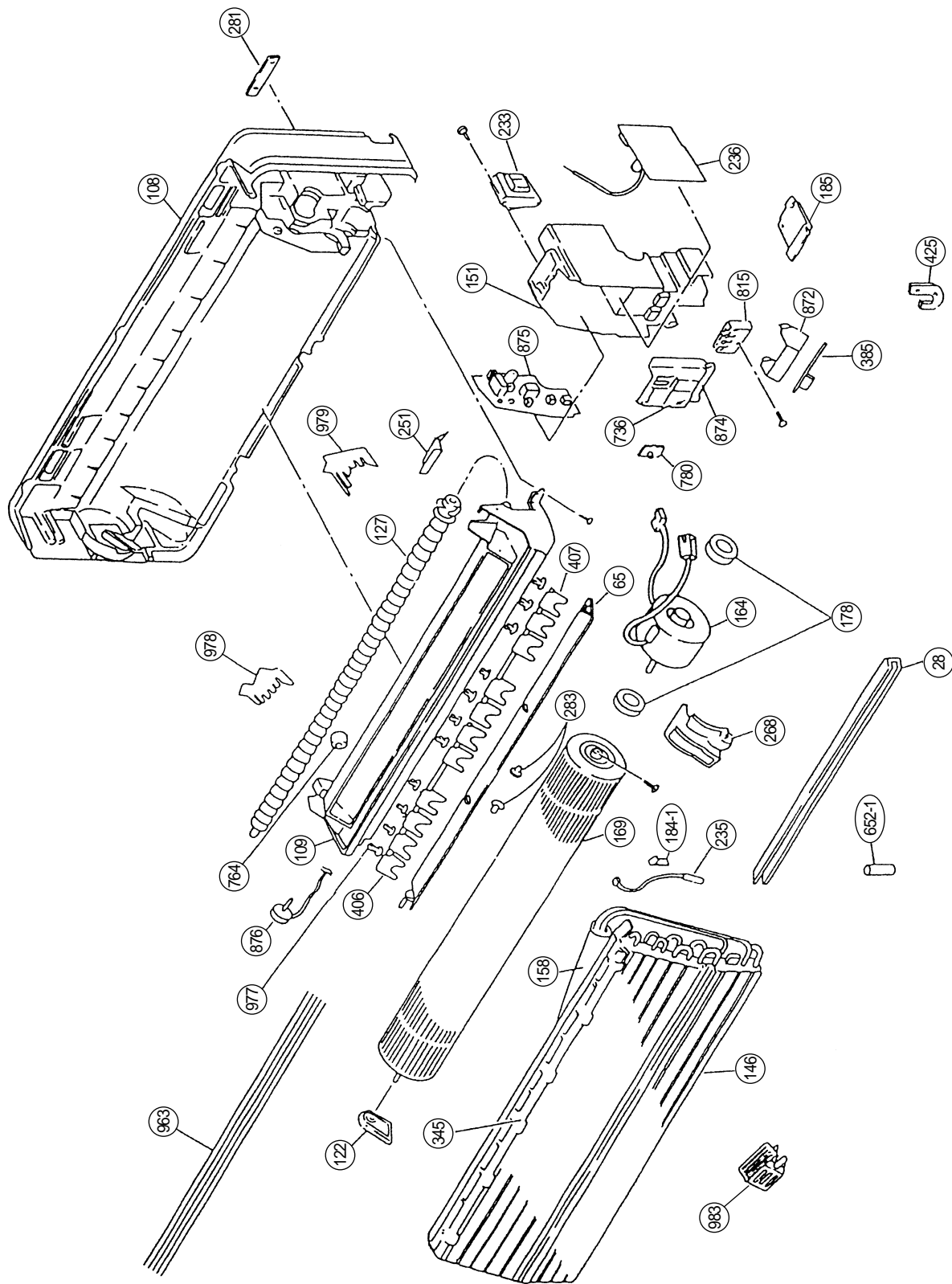

Model : ROW-17AC

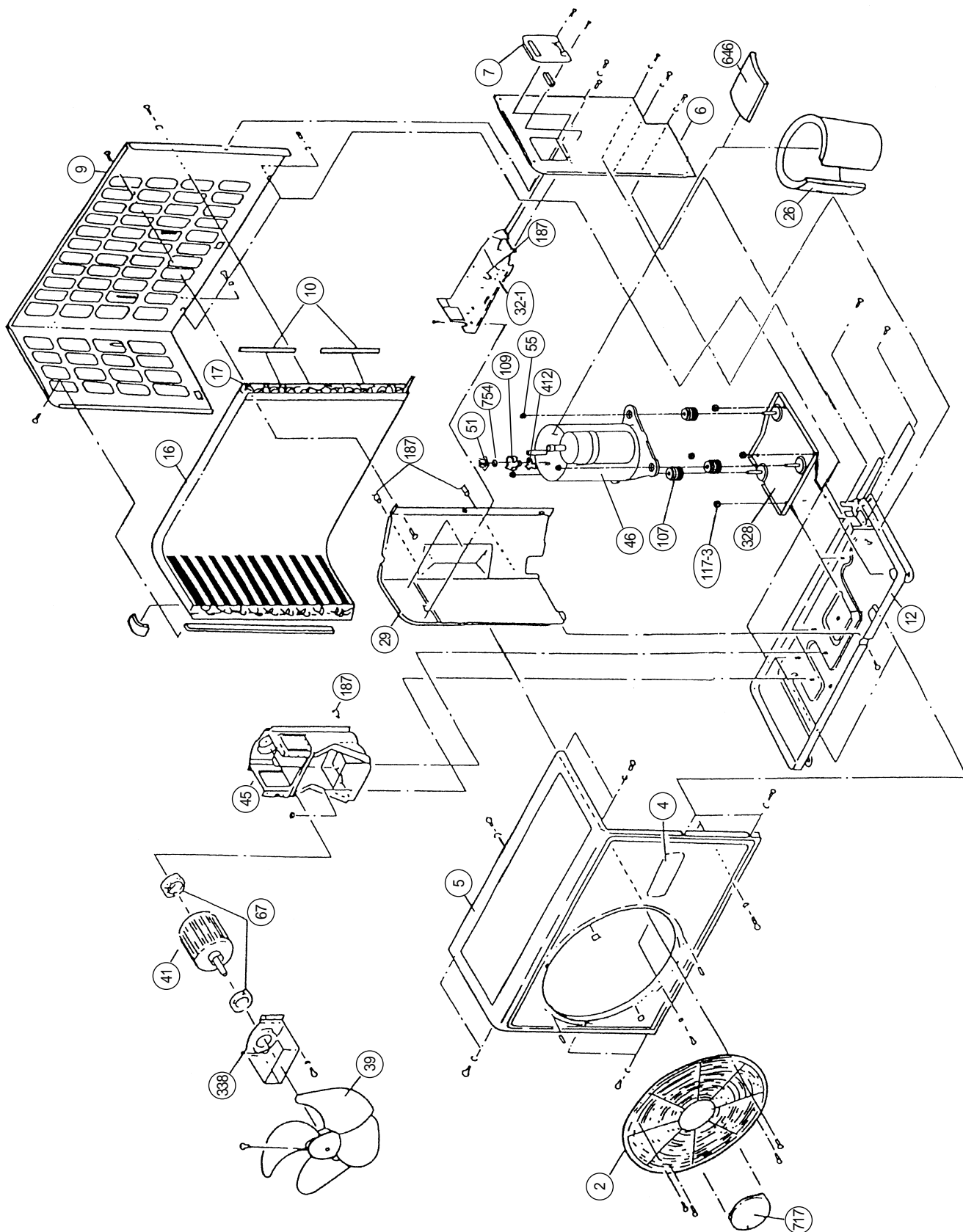

Model : ROW-17AC

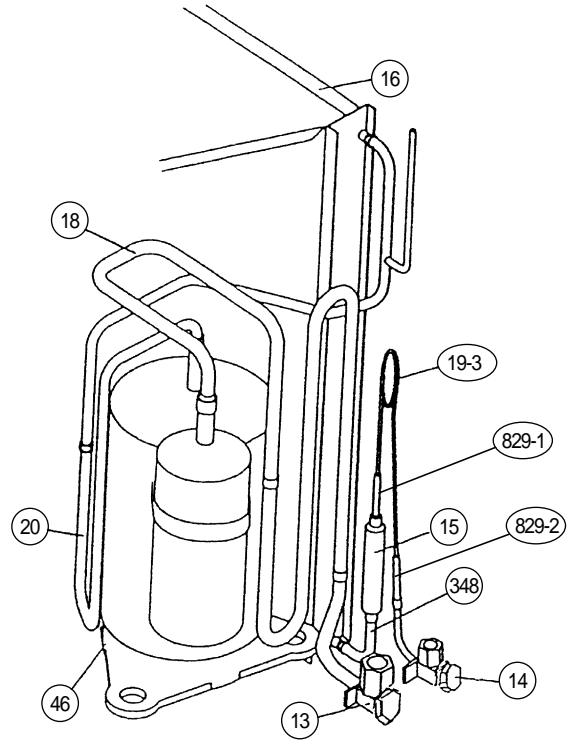
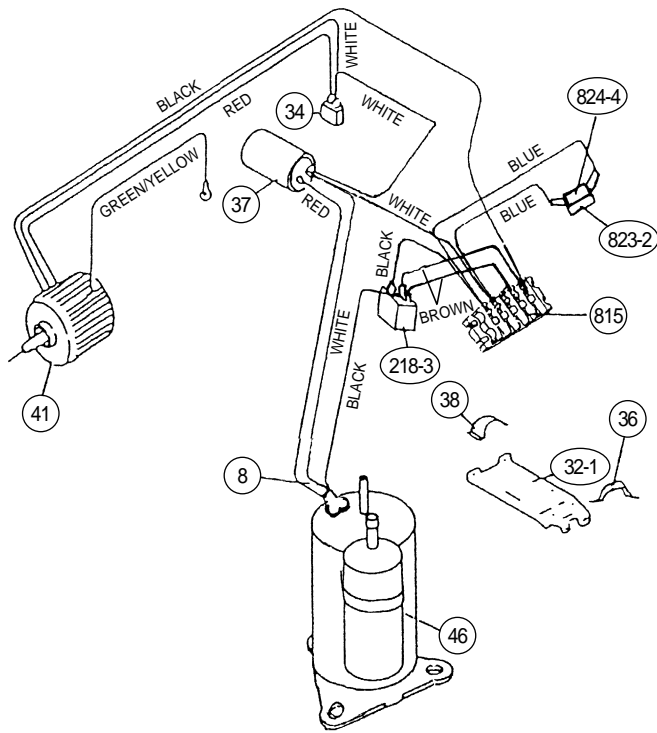

PARTS LIST

When you order parts, please make a photocopy of this page and fill the number of the parts in the "Order" column.

INDOOR UNIT

Ref. No.	Description	Part No.	Ord. Q'ty	Ref. No.	Description	Part No.	Ord. Q'ty
		RSW-17AC				RSW-17AC	
28	Blower Cover	9304111016		406	Louver-L Assy	9354644014	
63	Front Panel Assy "FUJI ELECTRIC"	9354229174		407	Louver-R Assy	9354643017	
65	Flow Control Panel	9354646063		425	Earth Terminal	9357852003	
74	Filter	9304097013		652-1	Thermistor Holder Pipe	313714262805	
108	Base	9304107033		736	Operation Panel	9354230002	
109	Casing	9304108016		743	Remote Control Unit Holder Case	9305642014	
122	Shaft Holder-B Assy	9304470007		758	Decoration Plate-A	9354223011	
127	Drain Hose Assy	9304761013		759	Intake Grille-B "FUJI ELECTRIC"	9355595063	
146	Evaporator Assy	9304589006		761	Side Cover-R	9303518076	
151	Control Box	9304092001		762	Side Cover-L	9303520147	
158	Connecting Pipe Assy	9304286011		764	Drain Cap Assy	9304150008	
164	Fan Motor Assy-In	9354513044		767-1	Bottom Cover-A	9303536056	
169	Cross-flow Fan Assy	9306327002		767-2	Bottom Cover-B	9303537053	
178	Motor Cushion-G	9304669005		780	Key Top (Slide Switch)	9303526002	
184-1	Thermostat Spring-A	313728262708		815	Terminal-3P	9701955046	
185	Wire Clamp	9356959000		848	Catcher	9306545000	
233	Power Transformer	9701803026		870	Arm	9303525005	
235	Thermistor Assy-Pipe	9702325015		871	Arm Spring	9304377009	
236	Controller PCB Assy	9701553051		872	Indicator Case	9303631003	
240	Remote Control Unit	9356765076		874	Control Box Cover	9304094005	
251	Hose Clamp	9304077008		875	Power Supply PCB Assy	9702451035	
268	Motor Cover-B	9304231004		876	Step Motor	9304535003	
281	Clamp Metal (Pipe)	9304242000		963	Fan Guard	9356881011	
283	Bushing-A	9303529010		977	Louver Clip, Plastic	9356880014	
345	Filter Guide	9304110019		978	Wire Bracket-L	9356878011	
385	Indicator PCB Assy	9701119011		979	Wire Bracket-R	9356877014	
401	Wall Hook Bracket	9304093008		983	Therm. Protect Cover	9356882001	

OUTDOOR UNIT

Ref. No.	Description	Part No.	Ord. Q'ty	Ref. No.	Description	Part No.	Ord. Q'ty
		ROW-17AC				ROW-17AC	
2	Fan Cover	9350214020		41	Fan Motor Assy-Out	9600738023	
4	Emblem-Rear	9361328006		45	Motor Fixing Table Assy	313029311100	
5	Cabinet-A, Painted	9303876015		46	Compressor Assy	9367240005	
6	Cabinet-C, Painted	9353549013		51	Special Nut M5	9300301015	
7	Connector Cover	9358011010		55	Special Nut M8	313252257701	
8	Wire Assy (Shield Tube)-D	9359904076		67	Rubber (Vibration-proof)	313659068604	
9	Cabinet-B, Painted	9303874011		107	Rubber Seat-A (For Comp.)	9351049010	
10	Noise Insulation-E	313791106305		109	Terminal Cover (For Comp.)	9351048013	
12	Base Assy, Painted	9353452054		117-3	Hex. Nut Washer Spring	301721180114	
13	3-Way Valve Assy	9364524009		187	Clamp No. 1219	313361271706	
14	2-Way Valve	9358023013		218-3	Power Relay	9704171016	
15	Dryer	9353789006		328	Compressor Plate-B	9363049015	
16	Condenser Assy	9353455055		338	Motor Fixture Metal	313029297108	
18	Suction Pipe	9365434000		348	Outlet Pipe	9363433005	
19-3	Capillary Tube (Cool)	9367295005		412	Terminal Gasket	9351051013	
20	Discharge Pipe Assy	9365435007		646	Compressor Cover-B	9363021004	
26	Compressor Cover-A	9363620007		717	Center Plate	9351253011	
29	Separate Wall	313986033213		754	Terminal Gasket Washer	9351053017	
32-1	Control Box Metal-A	9365672013		815	Terminal-5P	9356497021	
34	Capacitor (Fan Motor)	9357965017		823-2	Fuse Holder	0500063024	
36	Cord Holder Metal	9356934007		824-4	Fuse	0600222529	
37	Running Capacitor	9703107016		829-1	Joint Pipe (Capillary Tube)	9363435009	
38	Capacitor Clamp Metal	9351770013		829-2	Joint Pipe (Valve)	9363434002	
39	Propeller Fan Assy	9300855013					

When you order parts, please make a photocopy of this page and fill the number of the parts in the "Order" column.

CONTROLLER PCB ASSEMBLY (Ref. No. 236)

Ref. No.	Description	Part No.	Ord. Qty	Ref. No.	Description	Part No.	Ord. Qty
IC1	IC MB89625R-SH-680	1300413033		R35	Res. 1/10W 49.9kΩ±0.5%	0200344683	
IC2	IC NJM7805FA	0100462081		R51	Res. 1/10W 1.5kΩ±5%	0200212784	
IC3	IC NJM2904M	0100534054		JP2,JC1,3-7,9-12,17,18	Res. 0Ω	0200230016	
IC4	IC PST600CMTR	0101461120		C6	Cap. Elec. 25V 1000μF	0300631256	
IC5,6	IC MC1413DR2	0101736013		C9-14,20-25,32-34	Cap. Ceramic 0.1μF	1902783046	
IC7	IC S-93C46ADFJ-TB	0101919027		C19	Cap. Ceramic 1000pF	1902829072	
Q1	Xstr DTC124EKA	0000936033		C26,27	Cap. Ceramic 1μF	1800119015	
D5	Diode D1F60	0000208024		X1	Ceramic Resonator CST8.38MTW-TF01	1300116019	
R2,7,30-33	Res. 1/10W 22kΩ±5%	0200213095		BZ1	Buzzer PKM13EPY-4000-TF01	9701298013	
R3,24	Res. 1/10W 1kΩ±5%	0200212746		L1-3	EMI Filter BLM31A601SPT	0400119029	
R4	Res. 1/10W 4.7kΩ±5%	0200212906		JP5,7-9,13,14	Wire IPS-3002-4	1903332014	
R5,9-14,19,20,26-29,36-42	Res. 1/10W 10kΩ±5%	0200213019		CN8	Plug, PCB B5B-PH-K-S	0500200061	
R6	Res. 1/10W 33kΩ±5%	0200213132		CN9	Plug, PCB 175487-7	0500891016	
R8	Res. 1MΩ±5%	0200213491		CN11	Plug, PCB BS5P-SHF-1AA	0500898015	
R15	Res. 100kΩ±5%	0200213255		CN12	Thermistor (Room Temp.)	9700801023	
R16	Res. 1.8kΩ±5%	0200691725		CN13	Plug, PCB B2B-XH-A	0500005055	
R18	Res. 1.2kΩ±5%	0200691534		CN16	Plug, PCB 175487-8	0500891023	
R22,23	Res. 330Ω±5%	0200212623					
R25	Res. 1.2kΩ±5%	0201001769					
R34	Res. 1/10W 10kΩ±0.5%	0200344010					

POWER SUPPLY PCB ASSEMBLY (Ref. No. 875)









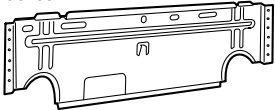

Ref. No.	Description	Part No.	Ord. Qty	Ref. No.	Description	Part No.	Ord. Qty
Q101	Xstr 2SD880	0000001014		L101	EMI Filter ELF15N008A	0400165071	
D101	Diode S1VB20	0000292054		SW101	Slide Switch 8SS1012-1	9701426010	
D102,103	Diode 1SR139-400	0000353137		SW102	Push Switch KSM0632B	9703476013	
D104	Diode RD16EB1	0000296014		F101	Fuse BET 3.15A-250V	0600222512	
R101	Res. Carbon 1/4W 1kΩ±5%	0201038758			Fuse Holder SN-5057	9700116011	
R102	Res. Carbon 1/4W 10kΩ±5%	0201005019		CN101	Plug, PCB 53405-0210	0500940011	
C101	Cap. Plastic 400V 1.3μF	0300939048		CN102	Plug, PCB B2B-XH-A	0500005055	
C102,103	Cap. Plastic 0.1μF	0300304075		CN103	Plug, PCB B2P3-VH-B	0500011728	
C104	Cap. Elec. 50V 2200μF	0301190981		CN105	Plug, PCB B3P5-VH-B	0500011735	
C105,111	Cap. Elec. 25V 10μF	0300099339		CN106	Plug, PCB B2P-VH-B	0500011124	
C107,108	Cap. Ceramic 0.1μF	0300988251		CN107	Wire w/Connector L=180	9701052011	
C109,110	Cap. Ceramic 4700pF	0300209110		JM101-103	Wire 0.6mm dia. L=10mm	9700025016	
VA101	Varistor TNR10V471K	0000361224		JM105	Wire 0.6mm dia. L=15mm	9700672012	
VA102	Arrester CP2470-F	9701835010		W101	Wire w/Terminal L=190 WHT	9703280016	
SSR101	Relay G3M-202PL-UTU	9701375011		E	Wire w/Terminal L=250 GRN	9701150014	
K101	Relay G4A-1A-E-PS	9703454011		HT	Heat Sink PUG-16	9701189014	

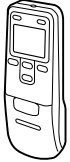
INDICATOR PCB ASSEMBLY (Ref. No. 385)

Ref. No.	Description	Part No.	Ord. Qty	Ref. No.	Description	Part No.	Ord. Qty
X201	Remote control Amplifier SBX1810-22	0101525129		CN201	Wire w/Connector L=250 Lamp Cover-A	9700923015 9303702000	
D201	Diode SLR-34LR RED	0000727013		C201	Cap. Ceramic 0.1μF	0300988251	
D202	Diode SLR-342MG GRN	0000727167		C202	Cap. Elec. 25V 10μF	0300328026	

STANDARD ACCESSORIES

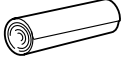
INDOOR UNIT ACCESSORIES

Name and Shape	RSW-17AC
Wall hook bracket 	9304093008
Wall cap 	313714296205
Remote control unit 	9356765076 (AR-AB25)
Battery (penlight) 	0600185534
Tapping screw (Big) (ø4 x 20) 	301141164200
Tapping screw (Small) (ø3 x 12) 	301141533125
Flange screw (ø4 x 10) 	9305114009
Remote control unit holder case 	9305642014
Cloth tape 	9304232001
Seal-A 	9304536000

OUTDOOR UNIT ACCESSORIES

Name and Shape	ROW-17AC
Hexagon wrench 	9351228019



MANUFACTURER :

Fuji Denki Sosetsu Co., Ltd

Tokyo, Japan



Большая библиотека технической документации

<https://splitsystema48.ru/instrukcii-po-ekspluatácii-kondicionerov.html>

каталоги, инструкции, сервисные мануалы, схемы.